

460kbps, 1 μ A, RS-232-Compatible Transceiver

General Description

The MAX3314 is a $\pm 5V$ powered EIA/TIA-232-compatible interface. It has one transmitter and one receiver in a flow-through architecture. The transmitter has a low-dropout output stage providing minimum RS-232-compatible $\pm 3.7V$ output levels while driving $3k\Omega$ and $1000pF$ at 460kbps. Both $+5V$ and $-5V$ are supplied externally.

The MAX3314 has a \overline{SHDN} function that reduces supply current to $1\mu A$. The transmitter is disabled and put into 3-state mode while the receiver remains active.

The MAX3314 is available in 8-pin SOT23, μ MAX and SO packages.

Features

- ◆ 1 μA Low-Power Shutdown with Receiver Active
- ◆ 30 μA Operating Supply Current
- ◆ 460kbps (min) Data Rate
- ◆ 8-Pin SOT23 Package
- ◆ RS-232-Compatible Levels

Ordering Information

PART	TEMP. RANGE	PIN-PACKAGE
MAX3314CKA	0°C to +70°C	8 SOT23
MAX3314CUA	0°C to +70°C	8 μ MAX
MAX3314CSA	0°C to +70°C	8 SO
MAX3314EKA	-40°C to +85°C	8 SOT23
MAX3314EUA	-40°C to +85°C	8 μ MAX
MAX3314ESA	-40°C to +85°C	8 SO

Applications

Digital Cameras
PDA
GPS
POS
Telecommunications
Handy Terminals
Set-Top Boxes

Pin Configuration

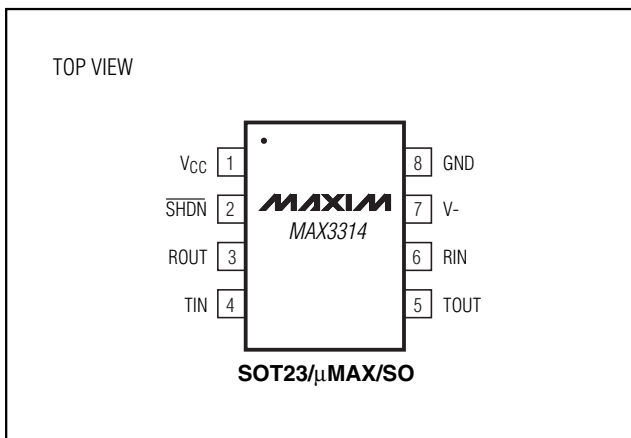

Typical Operating Circuit

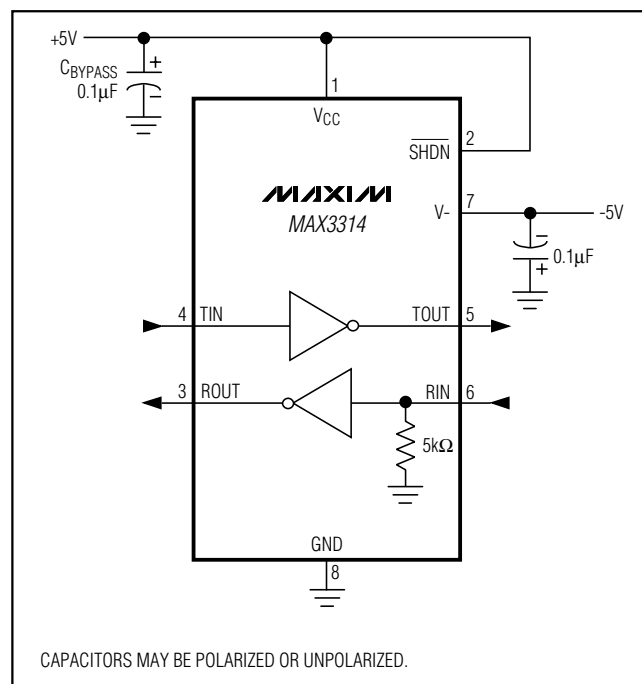

460kbps, 1 μ A, RS-232-Compatible Transceiver

ABSOLUTE MAXIMUM RATINGS

V _{CC} to GND	-0.3V to +6V	Continuous Power Dissipation	
V ₋ to GND	+0.3V to -6V	8-Pin SOT23 (derate 9.7mW/°C above +70°C).....	777mW
Input Voltages		8-Pin μ MAX (derate 4.1mW/°C above +70°C).....	300mW
TIN, SHDN to GND	-0.3V to +6V	8-Pin SO (derate 5.88mW/°C above +70°C).....	471mW
RIN to GND	\pm 25V	Operating Temperature Ranges	
Output Voltages		MAX3314C_A.....	0°C to +70°C
TOUT to GND.....	\pm 13.2V	MAX3314E_A.....	-40°C to +85°C
ROUT	-0.3V to (V _{CC} + 0.3V)	Junction Temperature	+150°C
Short-Circuit Duration		Storage Temperature Range	-65°C to +150°C
TOUT to GND	Continuous	Lead Temperature (soldering, 10s)	+300°C

Stresses beyond those listed under "Absolute Maximum Ratings" may cause permanent damage to the device. These are stress ratings only, and functional operation of the device at these or any other conditions beyond those indicated in the operational sections of the specifications is not implied. Exposure to absolute maximum rating conditions for extended periods may affect device reliability.

ELECTRICAL CHARACTERISTICS

(V_{CC} = +5V, V₋ = -5V, T_A = T_{MIN} to T_{MAX}, unless otherwise noted. Typical values are at T_A = +25°C.)

PARAMETER	SYMBOL	CONDITIONS	MIN	TYP	MAX	UNITS
DC CHARACTERISTICS						
Positive Supply Operating Range	V _{CC}		4.75	5	5.25	V
Negative Supply Operating Range	V ₋		-4.75	-5	-5.25	V
Positive Supply Current		$\overline{\text{SHDN}} = V_{CC}$, no load		30	100	μ A
Negative Supply Current		$\overline{\text{SHDN}} = V_{CC}$, no load		15	30	μ A
Shutdown Supply Current		$\overline{\text{SHDN}} = \text{GND}$		1	10	μ A
LOGIC INPUTS (TIN, SHDN)						
Input Logic Threshold Low	V _{IL}		0.8			V
Input Logic Threshold High	V _{IH}				2.4	V
Transmitter Input Hysteresis				0.5		V
Input Leakage Current				\pm 0.01		μ A
RECEIVER OUTPUT						
Output Voltage Low	V _{OL}	I _{OUT} = 1.6mA			0.4	V
Output Voltage High	V _{OH}	I _{OUT} = -1.0mA	V _{CC} - 0.3	V _{CC} - 0.1		V
RECEIVER INPUT						
Input Threshold Low	V _{IL}		0.8			V
Input Threshold High	V _{IH}				2.4	V
Input Hysteresis				0.5		V
Input Resistance				5		k Ω
TRANSMITTER OUTPUT						
Output Voltage Swing		Transmitter output loaded with 3k Ω to ground	\pm 3.7			V
Output Resistance (Note 1)		V _{CC} = V ₋ = 0, transmitter output = \pm 2V	300			Ω
Output Short-Circuit Current					\pm 60	mA
Output Leakage Current		V _{OUT} = \pm 12V, transmitter disabled			25	μ A

Note 1: Not tested—guaranteed by design.

460kbps, 1μA, RS-232-Compatible Transceiver

MAX3314

TIMING CHARACTERISTICS

(V_{CC} = +5V, V₋ = -5V, T_A = T_{MIN} to T_{MAX}, unless otherwise noted. Typical values are at T_A = +25°C.)

PARAMETER	SYMBOL	CONDITIONS	MIN	TYP	MAX	UNITS
Maximum Data Rate		R _L = 3kΩ, C _L = 1000pF, transmitter switching	460			kbps
Receiver Propagation Delay	t _{PLH}	Receiver input to receiver output, C _L = 150pF		0.15		μs
	t _{PHL}	Receiver input to receiver output, C _L = 150pF		0.15		
Transmitter Skew				100		ns
Receiver Skew				50		ns
Transition Region Slew Rate		R _L = 3kΩ to 7kΩ, C _L = 150pF to 1000pF, measured from +3V to -3V or from -3V to +3V		8		V/μs

Typical Operating Characteristics

(V_{CC} = +5V, V₋ = -5V, 250kbps data rate, transmitter loaded with 3kΩ and C_L, T_A = +25°C, unless otherwise noted.)

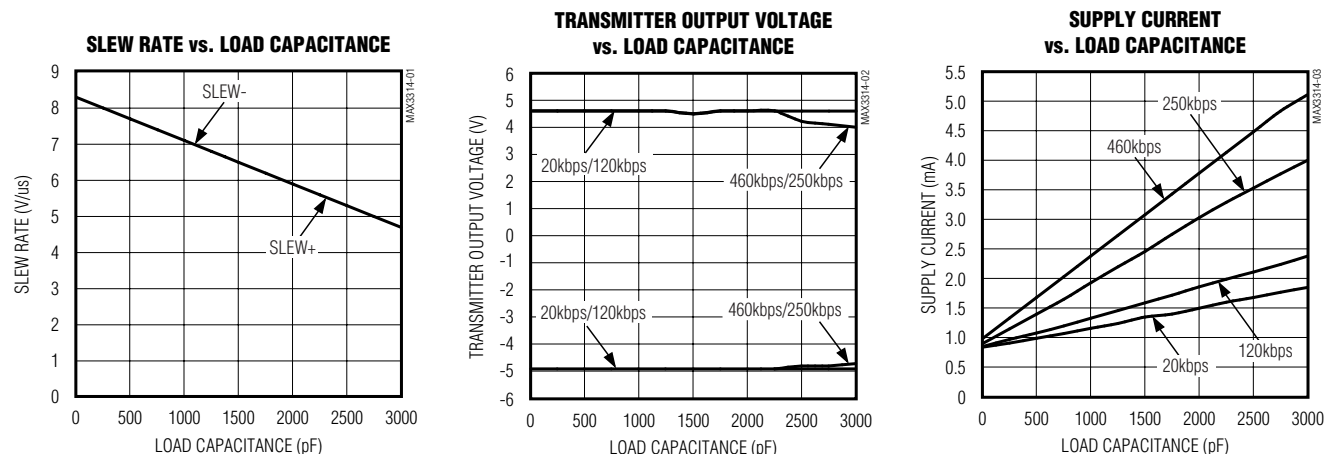

Pin Description

PIN	NAME	FUNCTION
1	V _{CC}	±5% External Power Supply. Decouple with a 0.1μF capacitor to ground.
2	$\overline{\text{SHDN}}$	Shutdown Active Low. 0 = OFF, 1 = ON.
3	ROUT	TTL/CMOS Receiver Output
4	TIN	TTL/CMOS Transmitter Input
5	TOUT	RS-232-Compatible Transmitter Output
6	RIN	RS-232-Compatible Receiver Input
7	V ₋	±5% External Power Supply. Decouple with a 0.1μF capacitor to ground.
8	GND	Ground

460kbps, 1μA, RS-232-Compatible Transceiver

Detailed Description

RS-232-Compatible Drivers

The transmitter is an inverting level translator that converts CMOS-logic levels to EIA/TIA-232-compatible levels. It guarantees data rates up to 460kbps with worst-case loads of 3kΩ in parallel with 1000pF. When $\overline{\text{SHDN}}$ is driven low, the transmitter is disabled and put into 3-state mode. The transmitter input does not have a pull-up resistor. Connect to ground if unused.

RS-232-Compatible Receivers

The MAX3314's receiver converts RS-232 signals to CMOS-logic output levels. The receiver is rated to signals up to ±25V. The MAX3314's receiver will remain active during shutdown mode.

MAX3314 Shutdown Mode

In shutdown mode, the transmitter output is put into high impedance. This reduces the supply current to 1μA. The time required to exit shutdown is less than 2.5μs. Table 1 is the shutdown logic truth table.

Table 1. Shutdown Logic Truth Table

$\overline{\text{SHDN}}$	TRANSMITTER OUTPUT	RECEIVER OUTPUT
L	High-Z	Active
H	Active	Active

Applications Information

Capacitor Selection

The capacitor type used is not critical for proper operation; either polarized or nonpolarized capacitors are acceptable. If polarized capacitors are used, connect polarity as shown in the *Typical Operating Circuit*.

Bypass VCC and V- to ground with at least 0.1μF.

Transmitter Output When Exiting Shutdown

Figure 1 shows the transmitter output when exiting shutdown mode. The transmitter is loaded with 3kΩ in parallel with 1000pF. The transmitter output displays no ringing or undesirable transients as the MAX3314 comes out of shutdown. Note that the transmitter is enabled only when the magnitude of V- exceeds approximately -3V.

High Data Rates

The MAX3314 maintains minimum RS-232-compatible ±3.7V transmitter output voltage even at high data rates.

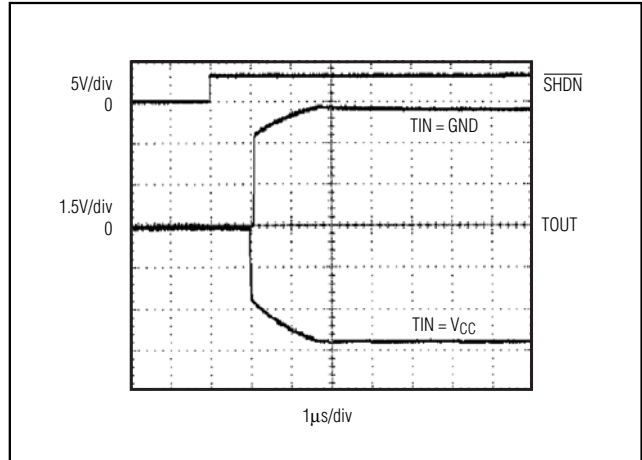

Figure 1. Transmitter Output When Exiting Shutdown or Powering Up

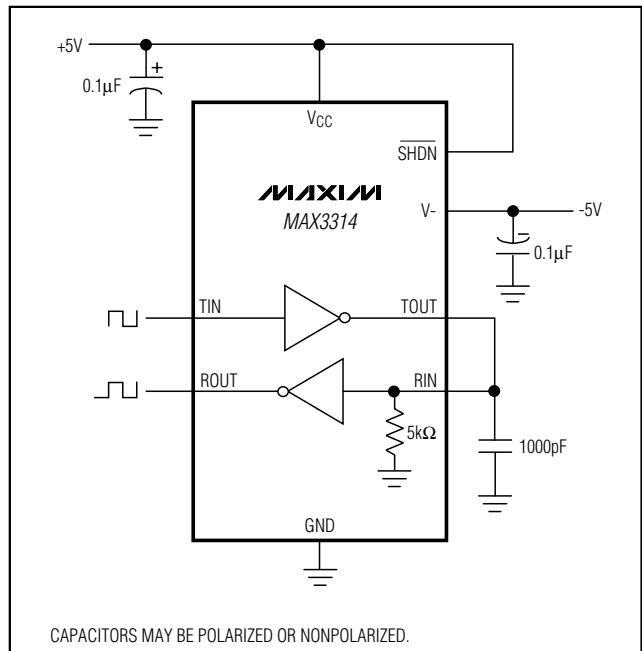

Figure 2. Loopback Test Circuit

Figure 2 shows a transmitter loopback test circuit. Figure 3 shows the loopback test result at 120kbps, and Figure 4 shows the same test at 250kbps.

Chip Information

TRANSISTOR COUNT: 128

460kbps, 1μA, RS-232-Compatible Transceiver

MAX3314

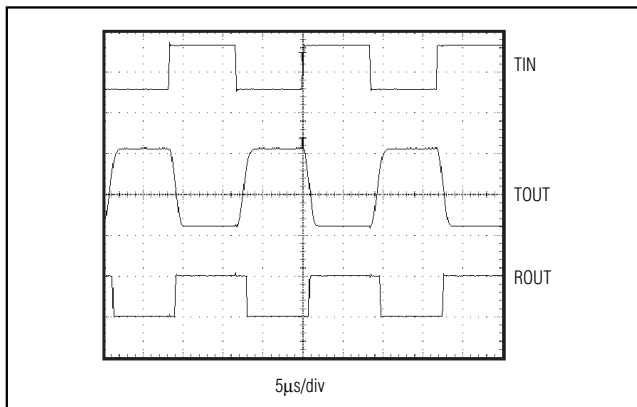

Figure 3. Loopback Test Results at 120kbps

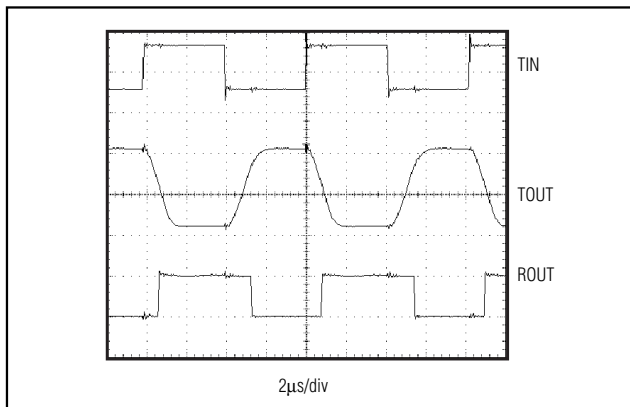
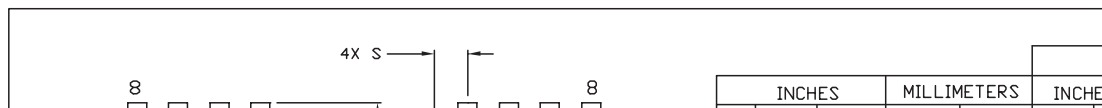

Figure 4. Loopback Test Results at 250kbps

Package Information



460kbps, 1μA, RS-232-Compatible Transceiver

Package Information (continued)

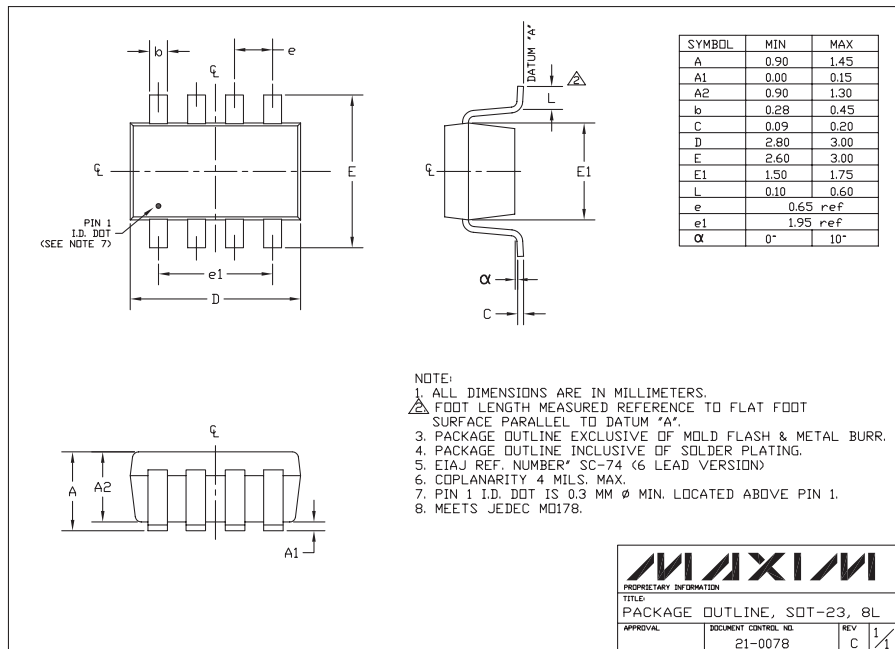
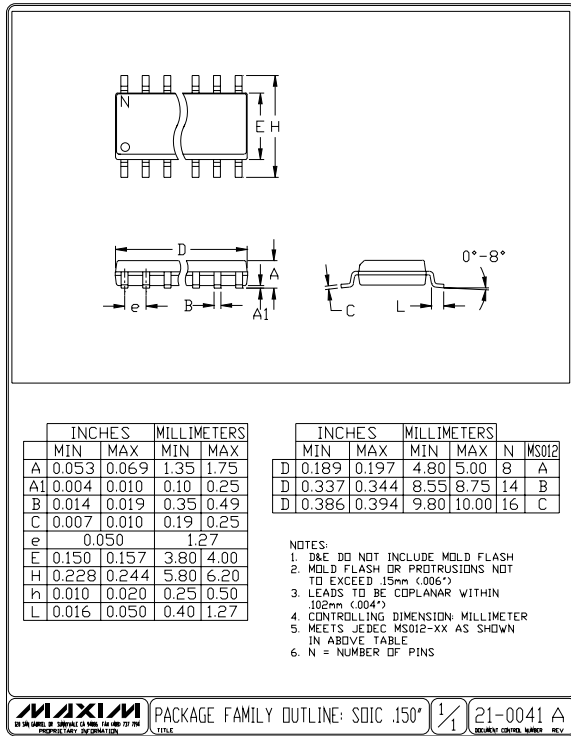

Maxim cannot assume responsibility for use of any circuitry other than circuitry entirely embodied in a Maxim product. No circuit patent licenses are implied. Maxim reserves the right to change the circuitry and specifications without notice at any time.

6 Maxim Integrated Products, 120 San Gabriel Drive, Sunnyvale, CA 94086 408-737-7600